

100-V Input, 300-mA Synchronous Step-Down Voltage Regulator

Features

- Wide Supply Voltage: 4.5 V to 100 V
- Advanced Fixed-Frequency Constant On-Time Regulation with External Resistor Setting
- Output Voltage Range: 1.225 V to 100 V
- Internal Power FET: 0.75 Ω and 0.4 Ω
- Load Current up to 300 mA
- 1.2-V Reference Voltage with 2% Accuracy
- High-Efficiency Synchronous-Mode Operation
- 100- μ A Quiescent Current
- 5-V Internal Regulator with 30-V Tolerance
- Internal Fixed 2-ms Soft-Start Timer
- Light Load Operation Mode
 - Forced PWM Mode (TPP00031)
 - Advanced Pulse Skip Mode (TPP00032)
- Over-Current Protection with Hiccup Mode
- Output over Voltage Protection
- Thermal Shutdown
- Small Outline Package with Exposed Pad
ESOP8 / DFN4X4-8 / DFN3X3-8
- -40°C to 125°C Operation Ambient Temperature Range

Applications

- 12-V, 24-V, 48-V Distributed Power Supply
- Telecommunication Applications
- Power Supply Unit Applications
- Isolated Power Supply

Description

The TPP00031/2 is a 300-mA output, synchronous, step-down, switching converter with internal power MOSFETs.

The TPP00031/2 series integrates power transistors with internal soft-start, compensation, and protection features. The constant on-time control scheme helps to improve fast transient response without the need of a compensation network. The TPP00031/2 offers a very compact solution to achieve a 300-mA continuous output current over a wide input supply range, with excellent load and line regulation.

The device has an internal low-voltage internal regulator voltage with minimal supply voltage as low as 4.5 V. The internal regulator voltage can be supplied with output voltage via a diode path to further improve efficiency.

The TPP00031/2 series has different light load configurations supporting both forced-PWM mode (TPP00031) for fixed switching frequency and pulse-skip mode (TPP00032) to save quiescent current.

The device is available in the 8-pin ESOP8, DFN4X4-8, and DFN3X3-8 packages with the support of a wide operation ambient temperature range from -40 °C to 125 °C.

Typical Application Circuit

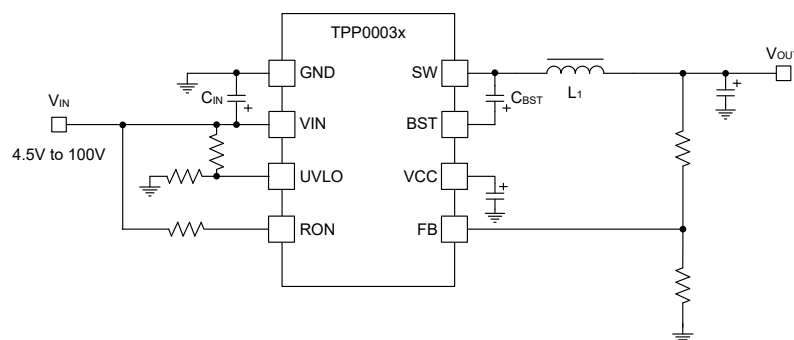

Table of Contents

Features	1
Applications	1
Description	1
Typical Application Circuit	1
Revision History	3
Pin Configuration and Functions	4
Specifications	5
Absolute Maximum Ratings ⁽¹⁾	5
ESD, Electrostatic Discharge Protection.....	5
Recommended Operating Conditions.....	6
Thermal Information.....	6
Electrical Characteristics.....	7
Typical Performance Characteristics.....	9
Detailed Description	11
Overview.....	11
Functional Block Diagram.....	12
Feature Description.....	12
Application and Implementation	15
Application Information	15
Typical Application.....	15
Layout	18
Layout Guideline.....	18
Layout Recommendations.....	18
Tape and Reel Information	19
Package Outline Dimensions	20
ESOP8.....	20
Order Information	21
IMPORTANT NOTICE AND DISCLAIMER	22

Revision History

Date	Revision	Notes
2024-01-24	Rev.A.0	Initial release

Pin Configuration and Functions

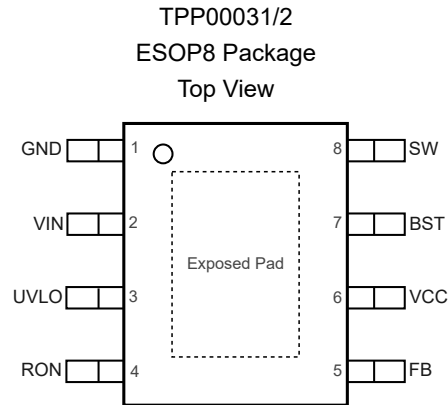

Table 1. Pin Functions: TPP00031/2

Pin	Name	I/O	Description
1	GND	G	Ground pin. Power and controller circuit ground. Use star connection to GND pin with good contact.
2	VIN	P	Supply input pin. Place 2×10-μF and 1×100-nF capacitors close to VIN
3	UVLO	I	Resistor divider input from VIN to set undervoltage protection threshold. When the UVLO pin is pulled below 0.66V, the device is shutdown.
4	RON	I	Connect a resistor between RON and VIN to set on-time.
5	FB	I	Feedback input pin. Connect the resistor divider from the output voltage to FB.
6	VCC	O	Internal regulator voltage output. Connect a 1-μF decoupling capacitor to GND.
7	BST	I	Boot strap node. Connect a 10-pF ceramic capacitor between BST and SW
8	SW	P	Switching node. Connect to output inductor and bootstrap capacitor.
	EP	-	Exposed pad. Connect to GND panel and to ground metal for thermal performance.

100-V Input, 300-mA Synchronous Step-Down Voltage Regulator
Specifications
Absolute Maximum Ratings ⁽¹⁾

Parameter		Min	Max	Unit
V _{IN}	Supply Voltage	-0.3	100	V
SW	Switching Node Voltage	-0.3	V _{IN} + 0.3	V
	Switching Node Voltage (100 ns)	-3	V _{IN} + 0.3	V
	Switching Node Voltage (50 ns)	-5	V _{IN} + 0.3	V
V _{UVLO}	UVLO Voltage	-0.3	100	V
V _{CC}	VCC Voltage	-0.3	30	V
VBST -SW	Bootstrap Voltage	-0.3	6	V
FB	Feedback Voltage	-0.3	6	V
V _{RON}	On-time Setting Voltage	-0.3	100	V
T _J	Maximum Junction Temperature	-40	150	°C
T _A	Operating Temperature Range	-40	125	°C
T _{STG}	Storage Temperature Range	-65	150	°C
T _L	Lead Temperature (Soldering 10 sec)		260	°C

- (1) Stresses beyond those listed under Absolute Maximum Ratings may cause permanent damage to the device. Exposure to any Absolute Maximum Rating condition for extended periods may affect device reliability and lifetime.
- (2) The inputs are protected by ESD protection diodes to each power supply. If the input extends more than 300 mV beyond the power supply, the input current should be limited to less than 10 mA.
- (3) A heat sink may be required to keep the junction temperature below the absolute maximum. This depends on the power supply voltage and how many amplifiers are shorted. Thermal resistance varies with the amount of PC board metal connected to the package. The specified values are for short traces connected to the leads.

ESD, Electrostatic Discharge Protection

Parameter	Condition	Minimum Level	Unit
HBM	ANSI/ESDA/JEDEC JS-001 ⁽¹⁾ All pins except VCC	2	kV
	ANSI/ESDA/JEDEC JS-001 ⁽¹⁾ VCC	1	kV
CDM	ANSI/ESDA/JEDEC JS-002 ⁽²⁾	1	kV

- (1) JEDEC document JEP155 states that 500-V HBM allows safe manufacturing with a standard ESD control process.
- (2) JEDEC document JEP157 states that 250-V CDM allows safe manufacturing with a standard ESD control process.

100-V Input, 300-mA Synchronous Step-Down Voltage Regulator**Recommended Operating Conditions**

Parameter		Min	Typ	Max	Unit
V _{IN}	Supply Input Voltage Range	4.5		100	V
T _J	Operating Junction Temperature	-40		150	°C

Thermal Information

Package Type	θ_{JA}	θ_{JC}	Unit
ESOP8	74	42	°C/W

100-V Input, 300-mA Synchronous Step-Down Voltage Regulator

Electrical Characteristics

All test conditions: $V_{IN} = 48\text{ V}$, $T_A = -40^\circ\text{C}$ to $+125^\circ\text{C}$, unless otherwise noted.

Parameter	Conditions	Min	Typ	Max	Unit	
Power Supply						
V_{IN}	Supply Voltage Range	4.5		100	V	
V_{CC}	Regulator Output	$V_{IN} = 48\text{ V}$, $I_{CC} = 20\text{ mA}$	3	3.6	4.4	V
I_{VCC_LIMIT}	VCC Current Limit	$V_{IN} = 48\text{ V}$	26			mA
V_{UVLO_VCC}	VCC UVLO Rising Edge		2.7	3.0	3.3	V
$V_{UVLO_VCC_HYS}$	VCC UVLO Hysteresis			170		mV
$V_{CC_Dropout}$	VCC Dropout Voltage	$V_{IN} = 5\text{ V}$, $I_{CC} = 20\text{ mA}$, $V_{IN} - V_{CC}$		2.6		V
I_Q	Operating Current	Non-switching current, VFB = 3 V, FCCM Mode, TPP00031		400	550	μA
		Non-switching current, VFB = 3 V, Pulse Skip Mode TPP00032		125	300	μA
ISD	Quiescent Current	Shutdown current		5	15	μA
Inputs (UVLO, EN)						
V_{UVLO_R}	UVLO Input Rising Threshold		1.19	1.225	1.26	V
V_{UVLO_F}	UVLO Input Falling Threshold		0.9	1.06	1.2	V
V_{RUVLO_F}	Remote UVLO Shutdown Threshold	UVLO Falling	0.45	0.76		V
V_{RUVLO_HYS}	Remote UVLO Shutdown Hysteresis			110		mV
Feedback and Power Stage						
V_{FB}	V_{FB} Feedback Voltage		1.181	1.2	1.218	V
$R_{ds(on)_HSD}$	High-side FET On-Resistance	$I_{SW} = 200\text{ mA}$, $BST - SW = 5\text{ V}$		0.7		Ω
$R_{ds(on)_LSD}$	Low-side FET On-Resistance	$I_{SW} = 200\text{ mA}$		0.3		Ω
$V_{BSTUVLO}$	Gate Driver Bootstrap UVLO Rising Threshold	$V_{BST} - V_{SW}$		2.8		V
$V_{BSTUVLO}$	Gate Driver Bootstrap UVLO Hysteresis			450		mV
T_{ON}	$V_{IN} = 6\text{ V}$, $R_{ON} = 100\text{ k}\Omega$			4360		ns
	$V_{IN} = 6\text{ V}$, $R_{ON} = 25\text{ k}\Omega$			1230		ns
	$V_{IN} = 12\text{ V}$, $R_{ON} = 100\text{ k}\Omega$			2300		ns
	$V_{IN} = 12\text{ V}$, $R_{ON} = 25\text{ k}\Omega$			640		ns
t_{SS}	Soft-Start Time			1.84		ms

100-V Input, 300-mA Synchronous Step-Down Voltage Regulator

Parameter		Conditions	Min	Typ	Max	Unit
Current Limit						
I _{Limit_HS}	High-side Current Limit	Inductor peak current		0.5		A
I _{Limit_LS}	Low-side Current Limit	Inductor valley current		0.25		A
Thermal Shutdown						
T _{SD}	Thermal Shut Down Temperature			160		°C
T _{SD_hys}	Thermal Hysteresis			10		°C

100-V Input, 300-mA Synchronous Step-Down Voltage Regulator

Typical Performance Characteristics

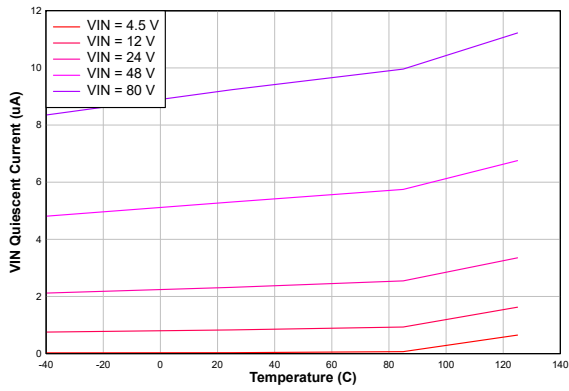

Figure 1. Quiescent Current vs. Temperature

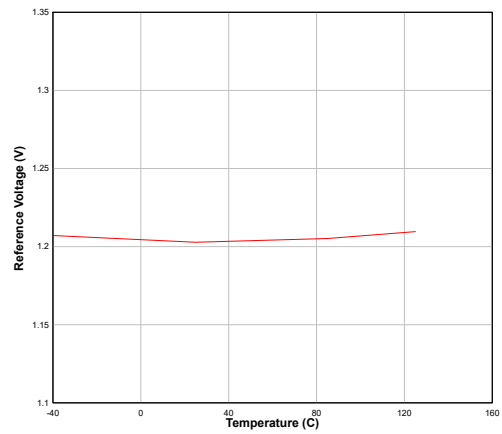

Figure 2. Reference Voltage vs. Temperature

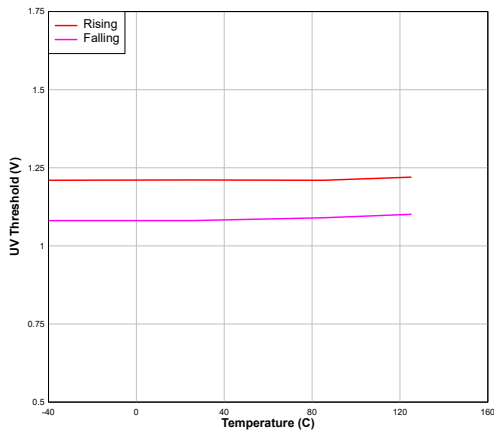

Figure 3. UV Threshold vs. Junction Temperature

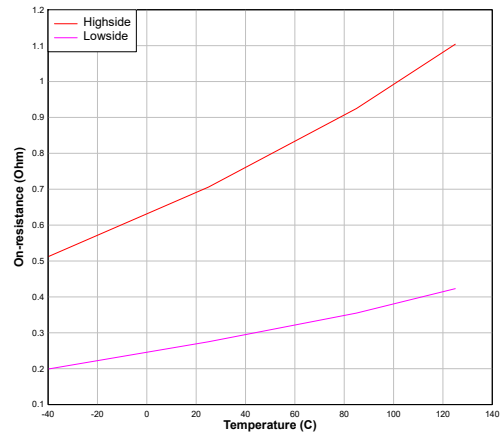

Figure 4. On-Resistance vs. Temperature

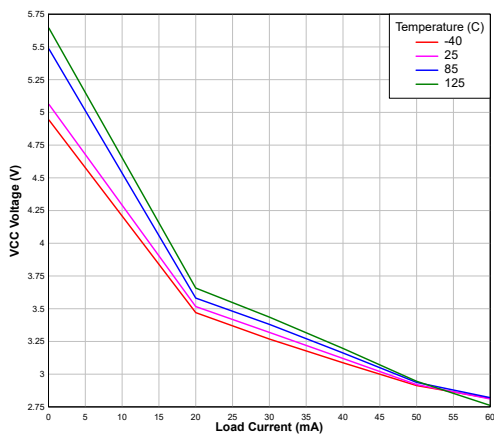

Figure 5. VCC vs. Load Current

VIN = 12 V

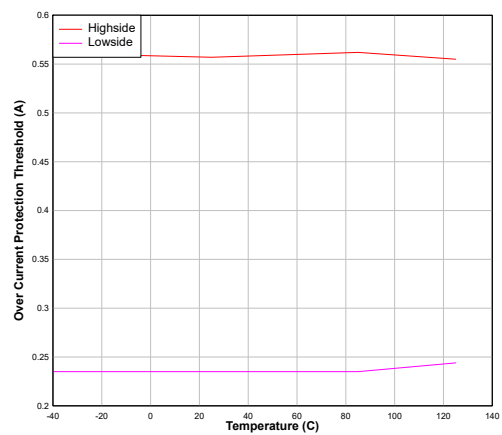

Figure 6. Current Limit vs. Temperature

100-V Input, 300-mA Synchronous Step-Down Voltage Regulator

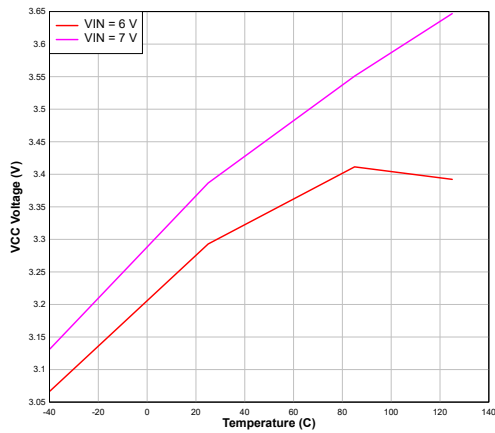

Figure 7. VCC vs. Junction Temperature

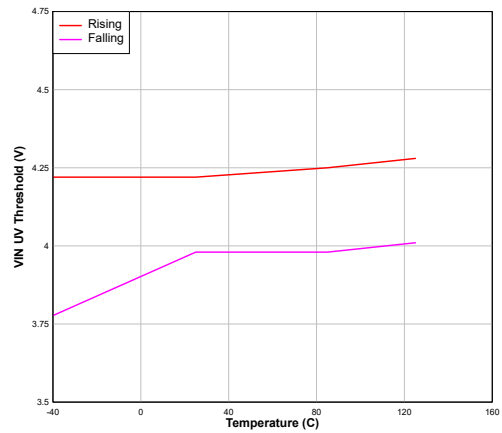

Figure 8. UVLO Threshold vs. Temperature

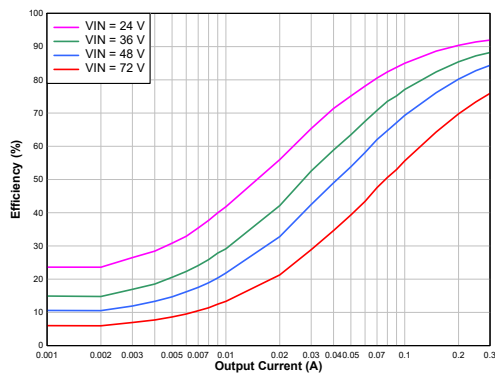

Figure 9. Efficiency vs. Output Current

 $V_{OUT} = 12\text{ V}$, TPP00031

Figure 10. Efficiency vs. Output Current

 $V_{OUT} = 12\text{ V}$, TPP00032

Figure 11. Load Regulation

 $V_{IN} = 72\text{ V}$, $V_{OUT} = 12\text{ V}$

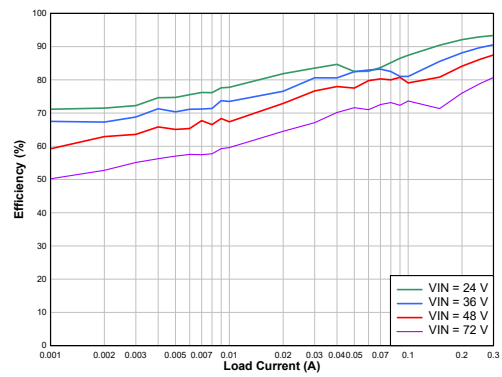
Figure 12. Line Regulation

 $I_{OUT} = 0.1\text{ A}$, $V_{OUT} = 12\text{ V}$

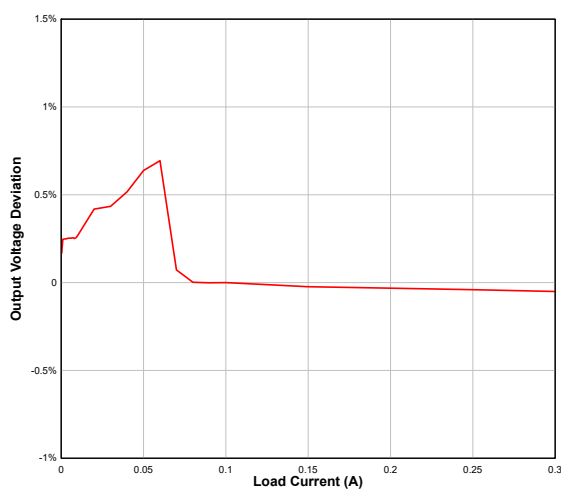
100-V Input, 300-mA Synchronous Step-Down Voltage Regulator

Detailed Description

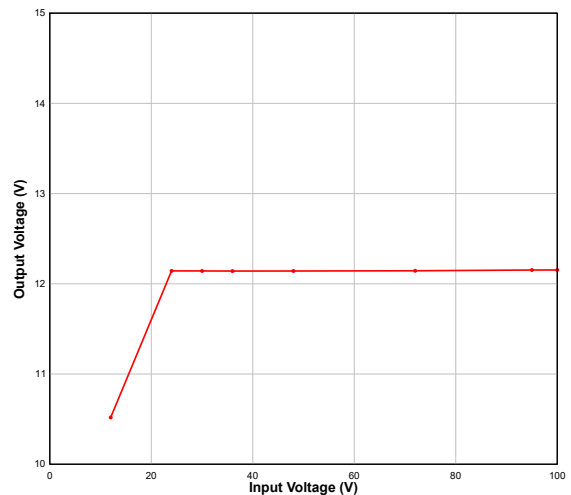
Overview

The TPP0003x is an advanced buck regulator, a step-down synchronous switching converter, designed to deliver a maximum load current of 300 mA. This regulator incorporates cutting-edge 100-V N-channel buck and synchronous rectifier switches. It offers two versions: the Forced-PWM version TPP00031 and the Pulse-Skip mode version TPP00032. Utilizing an innovative adaptive constant on-time control architecture, the regulator ensures a stable operating frequency across varying load conditions and input voltage ranges. Its fast load transient response enables seamless power delivery. The TPP0003x is available in the widely adopted industrial standard ESOP8 package with an exposed pad.

The TPM0003x solution efficiently meets power supply requirements in 24-V and 48-V industrial systems, offering reliable and precise power conversion for various applications. The TPM0003x incorporates advanced protection features to ensure safe and reliable operation. It incorporates an undervoltage lockout (UVLO) circuit to prevent the device from operating at low input voltages, while intelligent current limit and thermal shutdown mechanisms safeguard against overload and short circuit conditions. Short-circuit protection is achieved through a peak current limit detection circuit that adjusts the forced off-time in response to the output voltage (VOUT) and input voltage (VIN), minimizing current limit foldback. Additional protection features include thermal shutdown with automatic recovery, UVLO for VCC and gate drive, a minimum forced off-time, and remote shutdown capability.

Device	Low Output Current Mode
TPP00031-ES1R	Forced-PWM Mode
TPP00032-ES1R	Pulse-Skip Mode

Functional Block Diagram

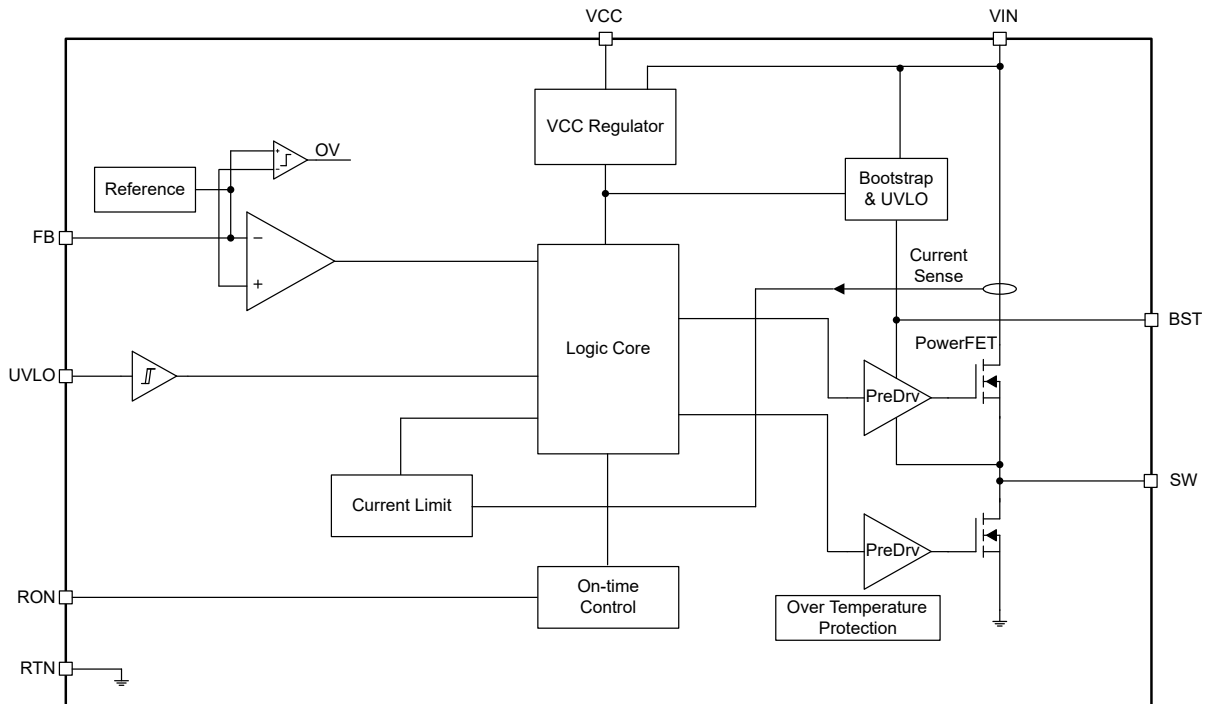

Figure 13. Functional Block Diagram

Feature Description

Adaptive Constant On-Time Control

The TPP0003x employs a constant on-time control scheme with an intelligent control logic to regulate the power converter's operation. In this control architecture, the on-time duration of the switch remains relatively constant regardless of load and input voltage variations.

The constant on-time control logic in TPP0003x operates by adjusting the off-time duration inversely with the input voltage (V_{IN}) and directly with the output voltage (V_{OUT}). This approach ensures a consistent operating frequency and efficient power conversion.

During normal operation, the feedback voltage at FB is compared to a 1.225-V reference in the TPP0003x. When the output voltage is in regulation, an on-time period is initiated when the FB voltage falls below 1.225 V. The high-side switch remains on for the on-time duration until the FB voltage rises above 1.225 V. The high side switch turns off until the FB voltage falls below 1.225 V again.

During start-up, the FB voltage is below 1.225 V at the end of each on-time. This immediately turns on the high side switch after the minimum forced off-time of 144 ns. The high-side switch can also be turned off before the on-time is completed if the peak current in the inductor reaches the current limit threshold.

The on-time for the TPP0003x device is determined by the R_{ON} resistor and is inversely proportional to the input voltage (V_{IN}). This characteristic ensures a nearly constant frequency as V_{IN} is varied within the operating range. The on-time for the TPP0003x can be calculated using the equation below.

100-V Input, 300-mA Synchronous Step-Down Voltage Regulator

$$T_{ON} = \frac{3.6 \times 10^{-10} \times R_{ON}}{V_{IN}} \quad (1)$$

To ensure proper operation, it is important to select an appropriate R_{ON} resistor for the TPP0003x. The chosen resistor should provide a minimum on-time (at maximum V_{IN}) greater than 100 ns, which may limit the maximum switching frequency for higher V_{IN} .

By maintaining a constant on-time, the TPP0003x achieves fast load transient response and eliminates the need for loop compensation, simplifying the design and reducing component count. The constant on-time control architecture also enhances stability and accuracy in regulating the output voltage.

V_{CC} Regulator

The TPP0003x device incorporates an internal high-voltage linear regulator with a nominal output of 4.5 V. It allows direct connection of the input pin (V_{IN}) to line voltages up to 100 V. The VCC regulator is internally current limited to 30 mA and supplies current to internal circuit blocks, including the synchronous MOSFET driver and logic circuits. The external capacitor at VCC receives current from the regulator.

The device also features an internal diode connecting VCC to the BST pin. This diode restores the charge in the gate drive bootstrap capacitor when the SW pin is low.

Once the voltage on the VCC pin reaches the undervoltage lockout (VCC UVLO) threshold, typically around 3 V, the IC is enabled.

These design elements in the TPP0003x ensure efficient voltage regulation and enable reliable operation across various applications.

In high input voltage scenarios, the power dissipated in the high voltage regulator of the TPP0003x can be significant and may limit the achievable output power. To address this, if the VCC voltage is externally driven by an alternate voltage source between 5 V and 30 V, the internal regulator is disabled. This helps reduce power dissipation within the IC and improves overall efficiency. By disabling the internal regulator, the TPP0003x provides a means to manage heat generation and optimize performance in high-input voltage applications.

In 5-V applications, the TPP0003x can still utilize a diode to maintain the internal voltage at 4.5 V. This diode ensures consistent VCC voltage even when a 5V input is used.

Output Driver

The TPP0003x integrates a high-side power transistor for efficient buck switching. It also incorporates a low-side power transistor for synchronous rectification. These power transistors work together to ensure continuous conduction mode and improve efficiency across a wide range of loads. The high-side power transistor, along with the floating high-voltage gate driver, external bootstrap capacitor, and internal high-voltage diode, enable effective buck switching operation. The low-side power transistor complements the high-side transistor by providing a path for the inductor current when the high-side transistor is turned off. This combination of high-side and low-side power transistors optimizes performance and simplifies circuitry in various technological applications.

Under-Voltage Lock Out

The TPP0003x device incorporates a dual-level undervoltage lockout (UVLO) circuit. When the UVLO pin voltage is below 0.66 V, the regulator enters a low current shutdown mode. In standby mode, with UVLO pin voltage between 0.66 V and 1.225 V, the VCC bias regulator remains active while the regulator output is disabled. Normal operation begins when the VCC pin exceeds the VCC undervoltage threshold and the UVLO pin voltage is greater than 1.225 V. The minimum operating voltage of the regulator can be set using an external voltage divider connected from V_{IN} to GND. These features enable flexible control and power management for various applications.

100-V Input, 300-mA Synchronous Step-Down Voltage Regulator

Output Over Voltage Protection

The TPP0003x incorporates Over Voltage Protection (OVP) functionality to ensure the safety and reliability of the system. The regulator constantly monitors the feedback voltage at FB and compares it to an internal 1.62-V reference. If the FB voltage rises above 1.62 V, indicating an over-voltage condition, the on-time pulse is immediately terminated. This safeguards the system from excessive voltage levels that may occur due to sudden changes in input voltage or output load. The high-side switch remains off until the FB voltage falls below 1.225 V, preventing any further activation until the voltage returns to a safe range. The OVP feature in the TPP0003x protects connected components and enhances overall system stability by preventing excessive output voltage.

Over Current Protection

The TPP0003x device incorporates a current limit off-timer for enhanced protection and efficient operation. If the current in the buck switch exceeds 1.02 A, the current cycle is immediately terminated, and a non-resettable off-timer is initiated. The duration of the off-time is controlled by the feedback voltage (FB) and the input voltage (VIN). This feature ensures safe short-circuit operation and provides reliable start-up behavior, even at the maximum input voltage of 100 V.

During overload conditions where the FB voltage is above zero volts (indicating a non-short circuit situation), the current limit off-time is reduced. This adjustment in the off-time during less severe overloads minimizes current limit foldback, reduces recovery time, and enhances start-up performance.

Over-Temperature Shutdown

Once the junction temperature rises above the internal over-temperature shutdown threshold, the device shuts off and recovers when the temperature falls below the threshold with hysteresis.

External Soft Start

The TPP0003x can incorporate a soft-start feature using an external circuit. This circuit typically consists of a capacitor (C1), resistors (R1 and R2), and a diode (D). During start-up, as capacitor C1 charges, the voltage at a specific node gradually decreases, allowing the switching operation to begin. The output voltage (VOUT) rises gradually to maintain the feedback voltage (FB) at a desired reference level. Once the voltage at the node reaches a certain threshold, indicating the completion of the soft-start process, the diode becomes reverse-biased. This soft-start mechanism ensures a controlled and smooth start-up, preventing excessive current and voltage spikes that could potentially affect the stability and reliability of the system.

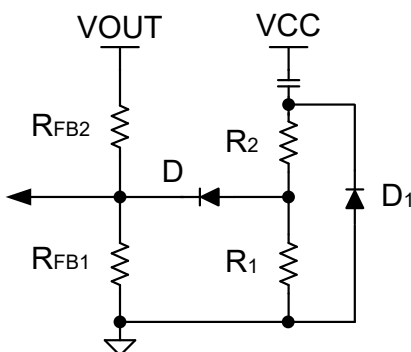

100-V Input, 300-mA Synchronous Step-Down Voltage Regulator

Application and Implementation

Note

Information in the following application sections is not part of the 3PEAK's component specification and 3PEAK does not warrant its accuracy or completeness. 3PEAK's customers are responsible for determining suitability of components for their purposes. Customers should validate and test their design implementation to confirm system functionality.

Application Information

As an easy-to-use step-down voltage regulator, also known as a buck regulator, the TPP0003x usually converts a higher input voltage to the desired output voltage set by the VFB resistor divider. The maximum output current is 300 mA. The below section depicts a simplified design flow of circuitry for the TPP0003x.

Typical Application

The TPP0003x is designed to handle input voltages up to 100 V, making it suitable for applications that require step-down voltage regulation to 12 V. With its capability to efficiently convert higher input voltages to a stable 12-V output, it can be used in a range of industrial, automotive, and electronic systems. Its versatility and high voltage handling capacity make it a reliable choice for delivering regulated 12-V power in diverse applications.

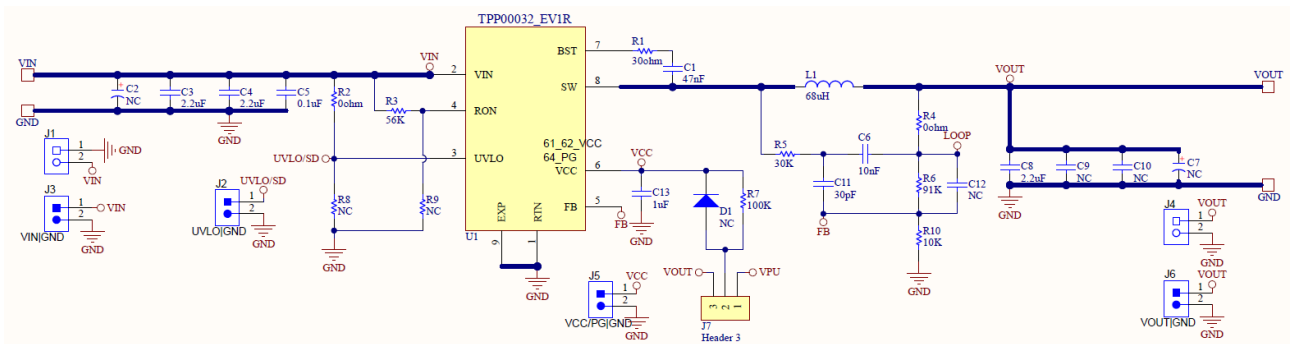

Figure 14. Typical Application Circuit

Component Selection

Designator	Value	Description	Package	MFR	Part No.	Qty
U1	TPP00032	Buck Converter, 100V, 0.3A	ESOP8	3PEAK	TPP00032-ES1R	1
C2	NC	NC				0
C3	2.2 μ F	Capacitor, 2.2 μ F, 250VDC, X7S, \pm 20%	2220	KEMET	C2220C225MA R2CTU	0
C4	2.2 μ F	Capacitor, 2.2 μ F, 250VDC, X7S, \pm 20%	2220	KEMET	C2220C225MA R2CTU	1

100-V Input, 300-mA Synchronous Step-Down Voltage Regulator

Designator	Value	Description	Package	MFR	Part No.	Qty
C5	0.1 μ F	Capacitor, 0.1 μ F, 250VDC, X7S, \pm 20%	1206	muRata	GRM31CR72E 104KW03L	1
R2	0 Ohm	Resistor, 0ohm, \pm 5%, 0.25W	0805	ROHM	SFR10EZPJ00 0	1
R8	NC	NC				
R3	56 kOhm	Resistor, 56kOhm, \pm 5%, 0.125W	0805	ROHM	KTR10EZPJ56 3	
R9	NC	NC				
R1	30 Ohm	Resistor, 30Ohm, \pm 1%, 0.4W	0805	ROHM	ESR10EZPF30 R0	1
C1	47 nF	Capacitor, 47nF, 50VDC, X7R, \pm 15%	0805	muRata	GCM21BR71H 473KA37L	0
C13	1 μ F	Capacitor, 1 μ F, 50VDC, X7R, \pm 10%	0805	muRata	GRM219R61H1 05KA73D	
D1	NC	NC				
R7	NC	NC				
L1	68 μ H	68 μ H, 3.2ARat, 3.6ASat, 89mohm	12.8 \times 12 \times 10mm	Wurth	7447709680	1
R5	30 kOhm	Resistor, 30kOhm, \pm 5%, 0.4W	0805	muRata	ESR10EZPJ30 3	
C6	10 nF	Capacitor, 10nF, 50VDC, X7R, \pm 1%	0805	muRata	GCM2195C1H1 03FA16D	1
C11	30 pF	Capacitor, 30pF, 50VDC, X7R, \pm 10%	0805	KEMET	C0805C300K5 RACAUTO	0
R4	0 Ohm	Resistor, 0ohm, \pm 5%, 0.25W	0805	ROHM	SFR10EZPJ00 0	1
R6	91 kOhm	Resistor, 91kOhm, \pm 1%, 0.4W	0805	ROHM	ESR10EZPF91 02	
R10	10 kOhm	Resistor, 10kOhm, \pm 1%, 0.4W	0805	ROHM	ESR10EZPF10 02	
C12	NC	NC				0

100-V Input, 300-mA Synchronous Step-Down Voltage Regulator

Designator	Value	Description	Package	MFR	Part No.	Qty
C8	2.2 μ F	Capacitor, 2.2 μ F, 50VDC, X7R, \pm 10%	0805	muRata	GRT21BR61H2 25KE13L	
C9	NC	NC				0
C10	NC	NC				0
C7	NC	NC				0

Layout

Layout Guideline

- Both input capacitors and output capacitors must be placed to the device pins as close as possible.
- It is recommended to bypass the input pin to ground with a 0.1- μ F bypass capacitor.
- It is recommended to use wide and thick copper to minimize $I \times R$ drop and heat dissipation.
- The exposed pad must be connected to the PCB ground plane directly, the copper area must be as large as possible.

Layout Recommendations

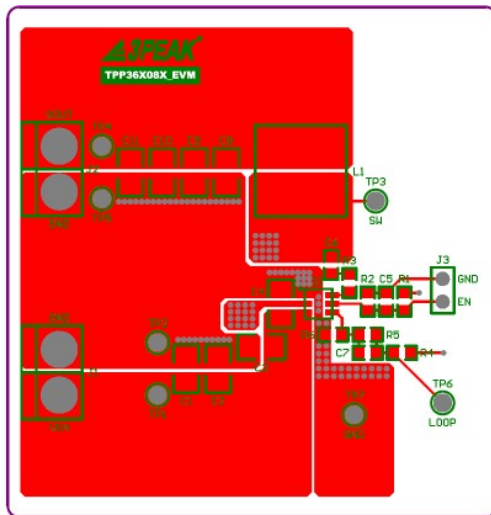

Top Layer

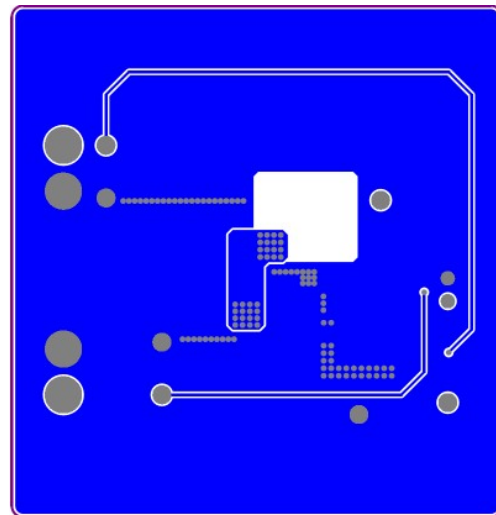

Bottom Layer

Tape and Reel Information

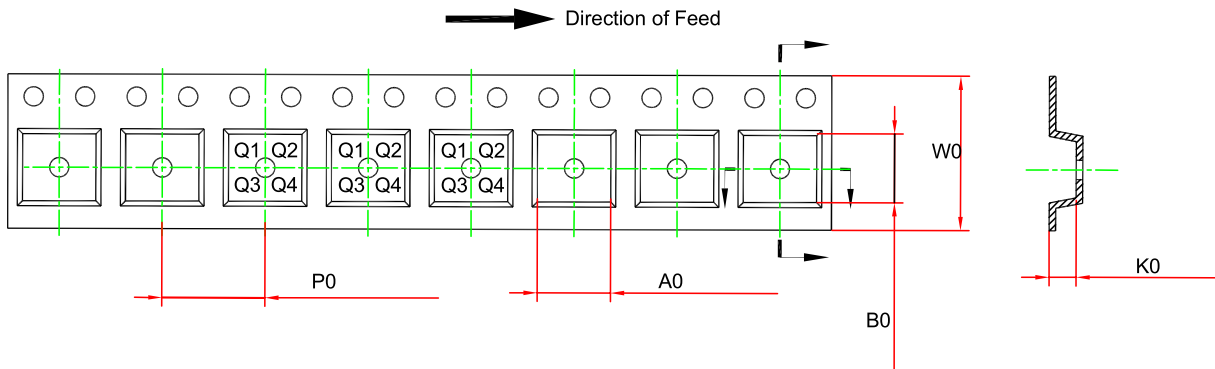
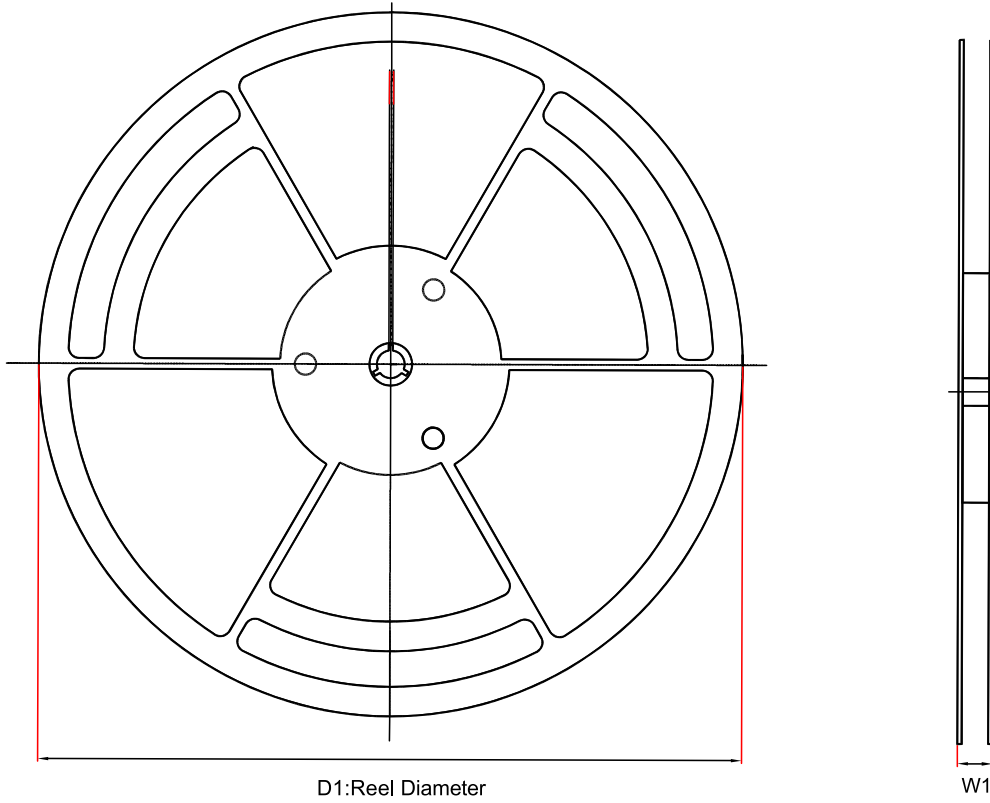

Order Number	Package	D1 (mm)	W1 (mm)	A0 (mm)	B0 (mm)	K0 (mm)	P0 (mm)	W0 (mm)	Pin1 Quadrant
TPP00031-ES1R	ESOP8	330	17.6	6.5	5.4	2.0	8.0	12.0	Q1
TPP00032-ES1R	ESOP8	330	17.6	6.5	5.4	2.0	8.0	12.0	Q1

Package Outline Dimensions

ESOP8

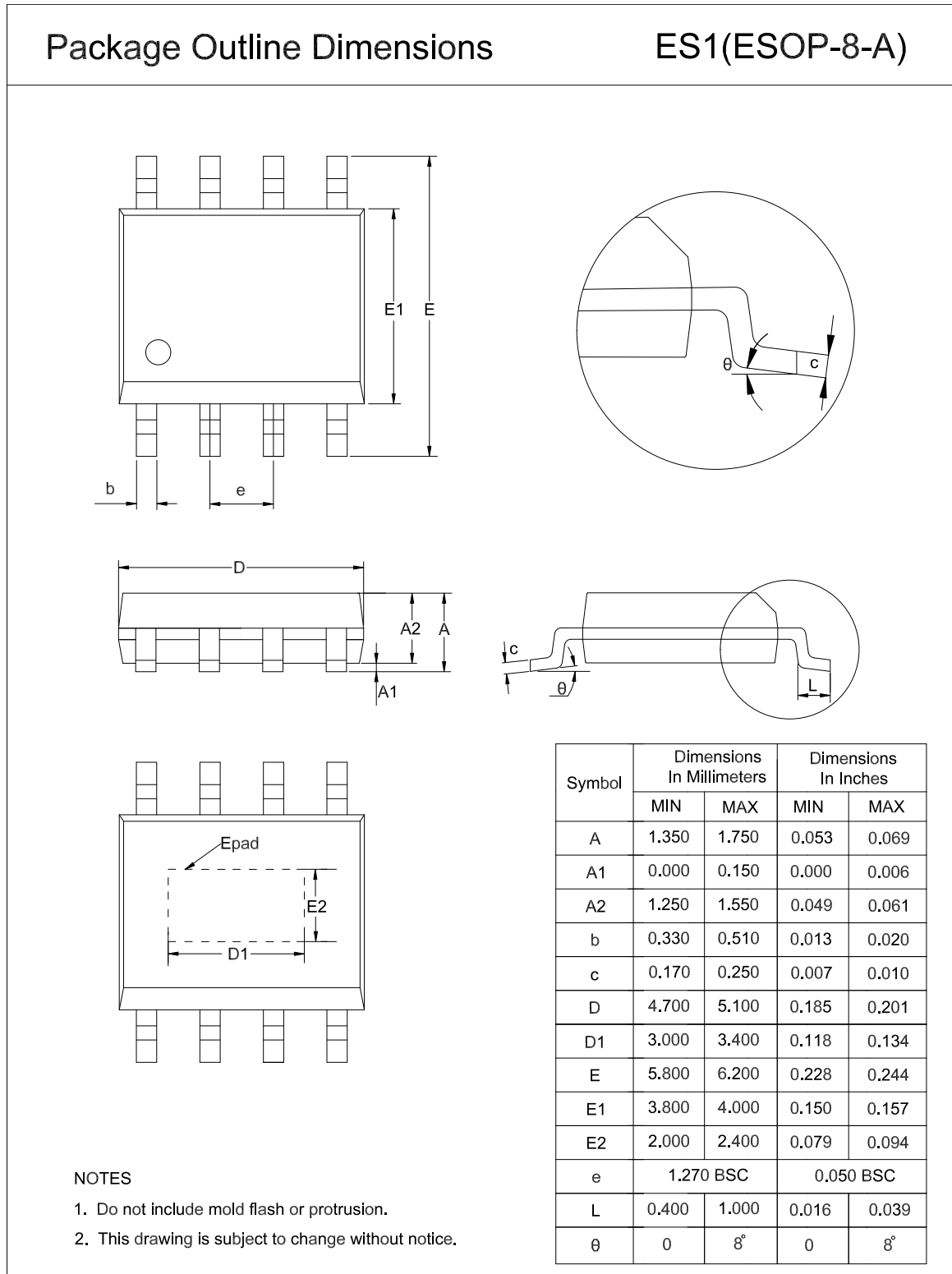

100-V Input, 300-mA Synchronous Step-Down Voltage Regulator**Order Information**

Order Number	Operating Temperature Range	Package	Marking Information	MSL	Transport Media, Quantity	Eco Plan
TPP00031-ES1R	-40 to 125°C	ESOP8	P0031	MSL3	Tape and Reel, 4000	Green
TPP00032-ES1R	-40 to 125°C	ESOP8	P0032	MSL3	Tape and Reel, 4000	Green

Green: 3PEAK defines "Green" to mean RoHS compatible and free of halogen substances.

IMPORTANT NOTICE AND DISCLAIMER

Copyright© 3PEAK 2012-2023. All rights reserved.

Trademarks. Any of the 思瑞浦 or 3PEAK trade names, trademarks, graphic marks, and domain names contained in this document /material are the property of 3PEAK. You may NOT reproduce, modify, publish, transmit or distribute any Trademark without the prior written consent of 3PEAK.

Performance Information. Performance tests or performance range contained in this document/material are either results of design simulation or actual tests conducted under designated testing environment. Any variation in testing environment or simulation environment, including but not limited to testing method, testing process or testing temperature, may affect actual performance of the product.

Disclaimer. 3PEAK provides technical and reliability data (including data sheets), design resources (including reference designs), application or other design recommendations, networking tools, security information and other resources "As Is". 3PEAK makes no warranty as to the absence of defects, and makes no warranties of any kind, express or implied, including without limitation, implied warranties as to merchantability, fitness for a particular purpose or non-infringement of any third-party's intellectual property rights. Unless otherwise specified in writing, products supplied by 3PEAK are not designed to be used in any life-threatening scenarios, including critical medical applications, automotive safety-critical systems, aviation, aerospace, or any situations where failure could result in bodily harm, loss of life, or significant property damage. 3PEAK disclaims all liability for any such unauthorized use.