

REV	ECN	DESCRIPTION	DATE	MODIFIED
1		PRE-RELEASE	Feb-20-17	JASON.C

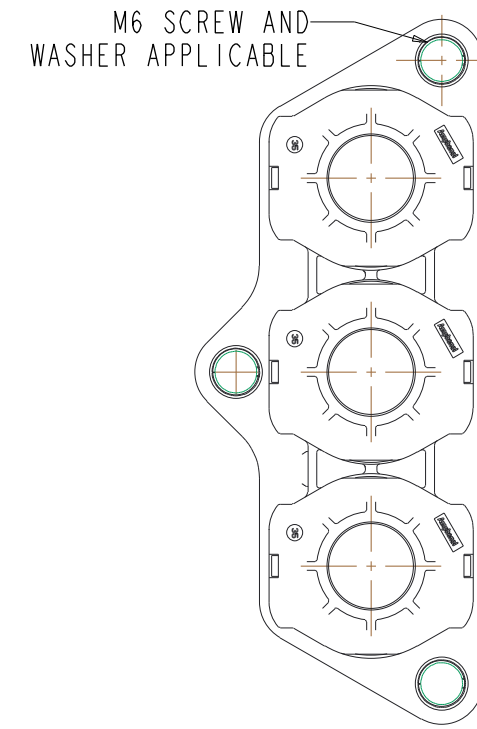
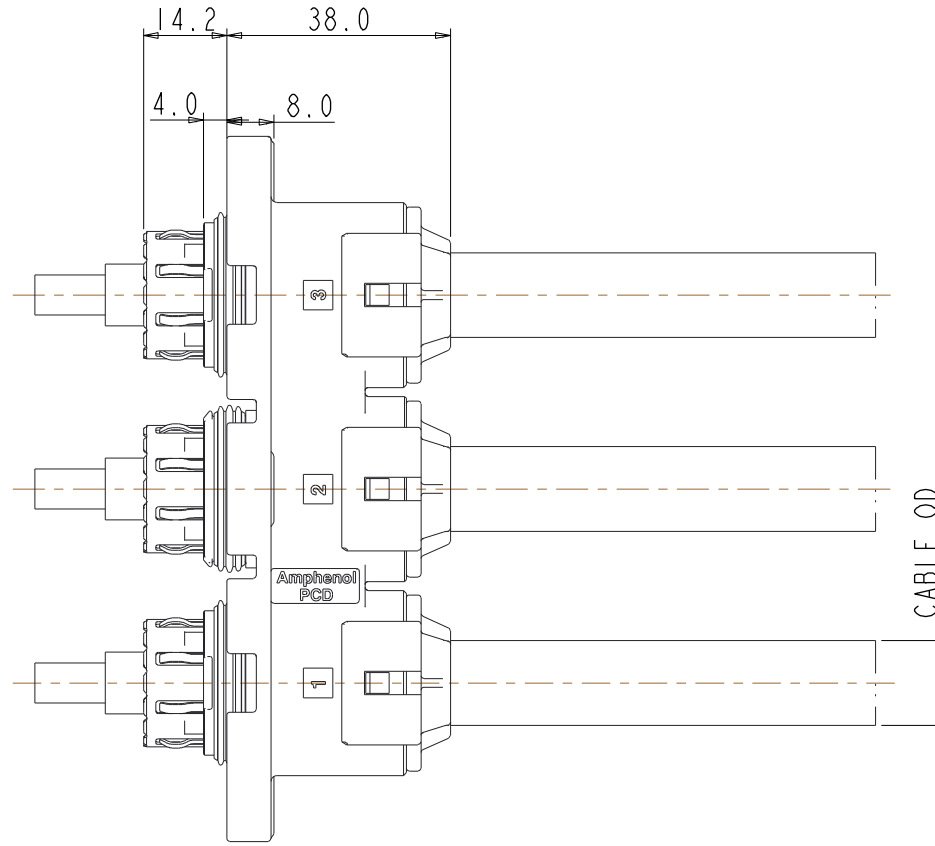
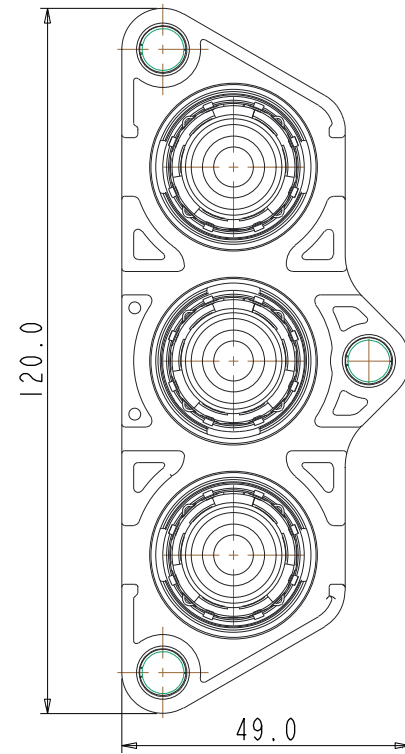

P03B00017

P03B00017

TECHNICAL DATA:	
CURRENT RATE 25mm <sup>2</sup> WIRE	120A
CURRENT RATE 35mm <sup>2</sup> WIRE	150A
CURRENT RATE 50mm <sup>2</sup> WIRE	180A
CURRENT RATE mm <sup>2</sup> WIRE	250A
UL RATING VOLTAGE	1000VDC
POLLUTION DEGREE 2	
OPERATING TEMPERATURE	-40-125° C
DIELECTRIC WITHSTANDING VOLTAGE	3000V
SHIELDING	YES
WATERPROOF	IP67
CORROSION-PROOF GRADE (SALT FOG TEST)	48 HOURS

**HVPTB 3 N XX**

25: FOR 25mm<sup>2</sup> Shielded WIRE; OD=11.9±0.3mm  
 35: FOR 35mm<sup>2</sup> Shielded WIRE; OD=14.2±0.3mm  
 50: FOR 50mm<sup>2</sup> Shielded WIRE; OD=16.5±0.3mm  
 70: FOR 70mm<sup>2</sup> Shielded WIRE; OD=19.0±0.3mm

DIMENSIONS	TOLERANCES	PROJECTION	TITLE		
ANSI Y14.5M UNITS: MM Pro/E FILE	X ±0.5 .XX ±0.25 ANGLES ±0.5°		Amphenol Pcd Shenzhen		
ORIGINAL NOT FOR CUSTOMER DISTRIBUTION	THIS DOCUMENT CONTAINS PROPRIETARY INFORMATION WHICH IS THE CONFIDENTIAL PROPERTY OF AMPHENOL PCD SHENZHEN	ENGR JASON.C Feb-20-17 CHKD APPD	SIZE	DWG NO.	REV
			A3	P03B00017	1
			CODE: 58982	SCALE: 3:10	SHEET 1 OF 2